



# **Fracarro, from the Disk of Nipkow to the Digital Convergence**

**HISTELCON 2008  
Paris, 11th-12th September**

## Fracarro, from the Disk of Nipkow to the Digital Convergence

Authors:

Walter Barbirato, Luca Morassutto  
Fracarro Radioindustrie S.p.A.

Massimo Temporelli  
National Museum of Science and Technology

## Historical Introduction

The dream of transmitting images, in addition to sounds, has been considered and studied since the distant 1880, and the best results were obtained in 1884 by a disk with a spiral pattern of holes punched through it. This was invented by a German physicist of Russian origins, Paul Gottlieb Nipkow, on 24th December 1883.

But Nipkow let his patents expire. Almost half a century passed before, on the other side of the English Channel, John Logie Baird started to reconsider that idea and created the first television of the history.

## Historical Introduction

The essential component to make the invention work well was the presence of a photoelectrical cell that had a sensibility similar to the retina of the human eye; thanks to the photoelectrical effect, the photocell created a transduction of the variations of luminous intensity in the electrical signal modulations.

The photocell, recorded the luminosity point by point of the object's various parts, reproducing each point with the correct intensity through a disk.

The disk turned luminous signals into electrical impulses and the receiving apparatus turned these impulses back into luminous flows and, that way, the process was closed.

## Historical Introduction

Given that, after each complete revolution of the two disks, the complete formation of the transmitted image was obtained, by rotating the two disks in perfect tune at the speed of 12 revolutions per second, a series of 12 complete images per second was obtained on the receiving screen.

## The mechanical television

In Italy it was the company of the brothers Giovanni and Bruno Fraccaro in Castelfranco Veneto (Italy) that, in the early 1930's, put in production and traded the first televisions based on a mechanical reception system with the Nipkow disk".

The two brothers proposed an assembly kit with which one could build his or her own mechanical television by using fan motors and radio valves.

## The mechanical television

The two enterprising radio amateurs made available to the public, for sale, the neon lamp and the Nipkow disk in aluminium and a very clear brochure titled “La televisione per tutti” for building the mechanical television.

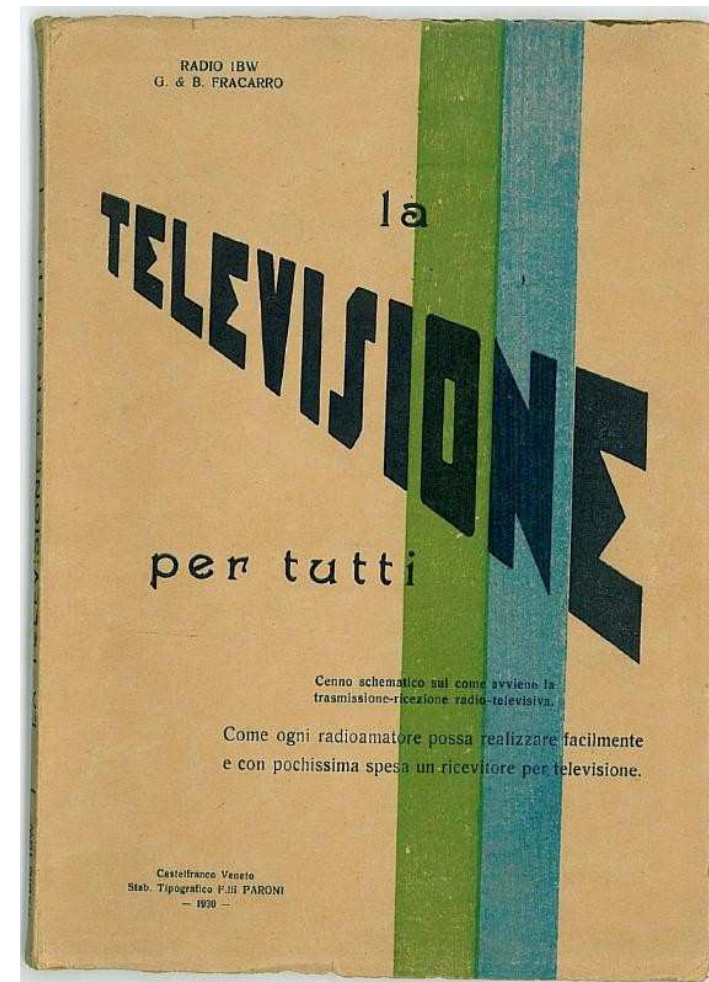

## The mechanical television

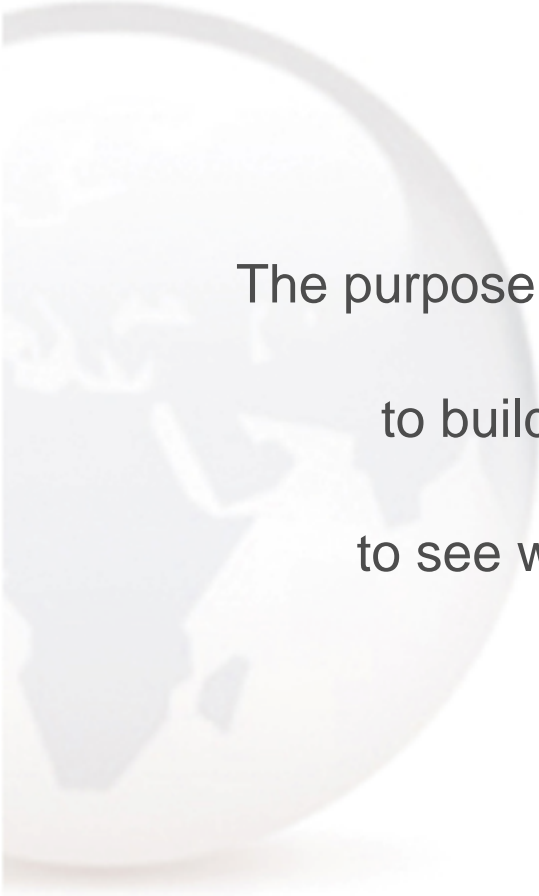

The purpose of the brochure was to allow every radio amateur to build easily and cheaply the simplest apparatus to see what was transmitted from the distant studios of the radio stations that diffused the television signal.

## From the mechanical television to the modern television

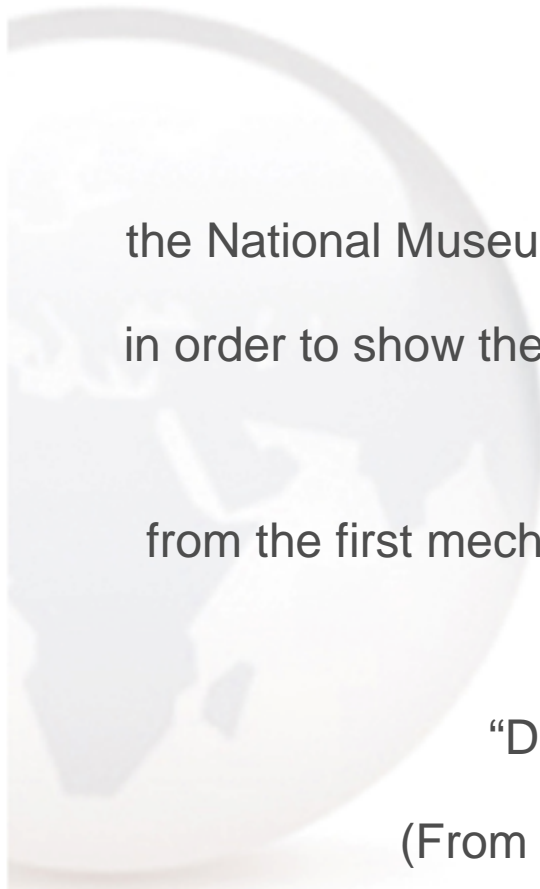
A large, faint, light-colored globe is visible in the background on the left side of the slide, showing the continents of Africa and Europe.

Starting from 24th September 2008,  
the National Museum of Sciences and Technology Leonardo Da Vinci in Milano,  
in order to show the evolution of technology for the production, transmission and  
reception of television images,  
from the first mechanical experimentations to modern digital technologies, has  
prepared an area titled  
“Dalla televisione meccanica a quella digitale”  
(From the mechanical television to modern television),  
exclusively devoted to Fracarro and the story of TV.

## From the mechanical television to the modern television

In this area there is a very rare prototype made by the brothers Giovanni and Bruno Fraccaro, equipped with a series of 10 Nipkow disks and the famous script made by the two enthusiastic radio amateurs, about whom we have talked.

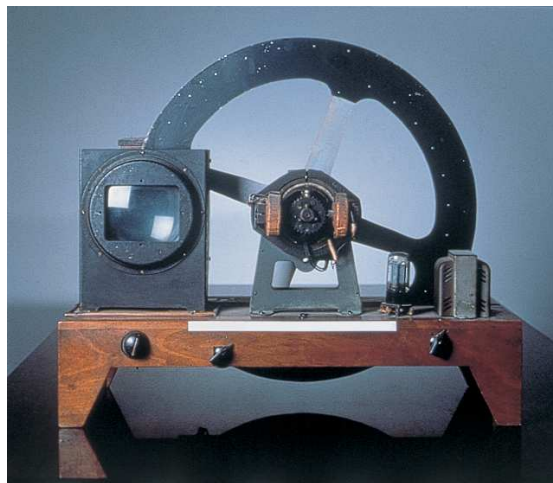

## From the mechanical television to the modern television

In that pioneer period, a few important programs were made, above all,  
by the BBC and Baird in England.

In particular, the wonderful and very rare work  
by Pirandello “L'uomo dal fiore in bocca” cast by BBC in 1929,  
in collaboration with Baird, will be shown to the visitors.

<http://www.tvdawn.com/mwfihtm.HTM>

## From the mechanical television to the modern television

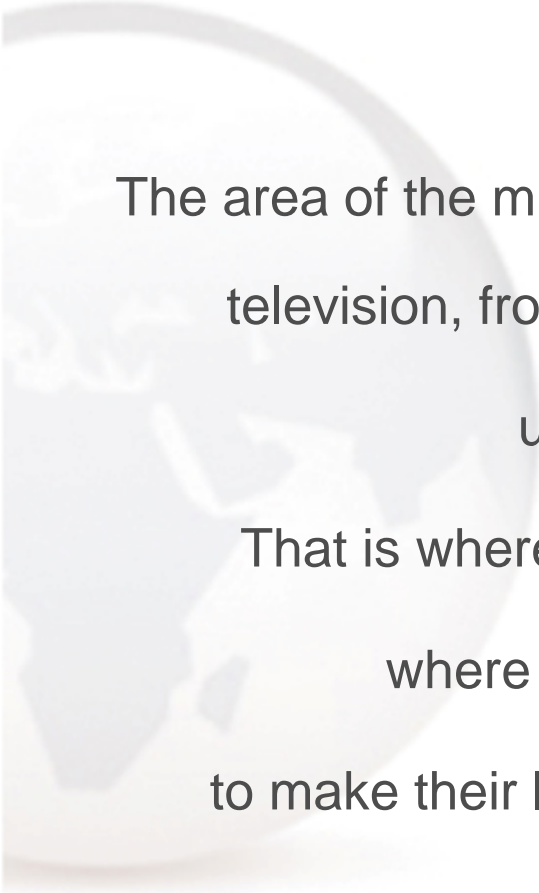
A large, faint, light-colored globe is visible in the background on the left side of the slide, showing the continents of Africa and Europe.

The area of the museum devoted to Fracarro covers all the history of the television, from the Nipkow disk to the digital terrestrial technology up to arrive at the digital convergence.

That is where Fracarro is going to create “intelligent” buildings where new services will be available for the users to make their lives easier as well as to manage the house easily.

## The convergence of technologies

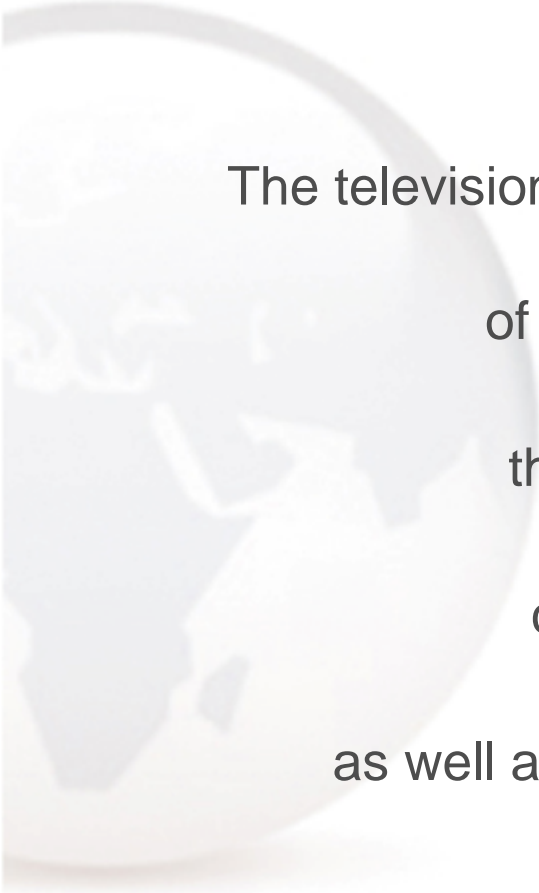

The television of the future goes beyond the traditional concept of passive use and becomes an interface through which the multimedial contents coming from traditional broadcasters, as well as Internet and home hard disks, can be used.

## The convergence of technologies

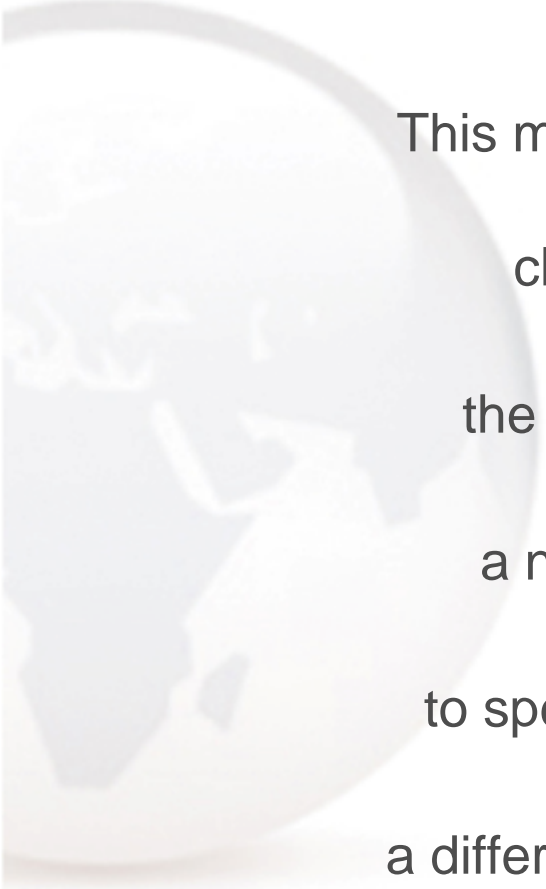

This means that, as the birth of the mechanic TV changed the history of communication, the digital convergence is similarly opening a new era where it is no longer an illusion to speak about “intelligent” buildings that allow a different way to communicate and use services.

## The convergence of technologies

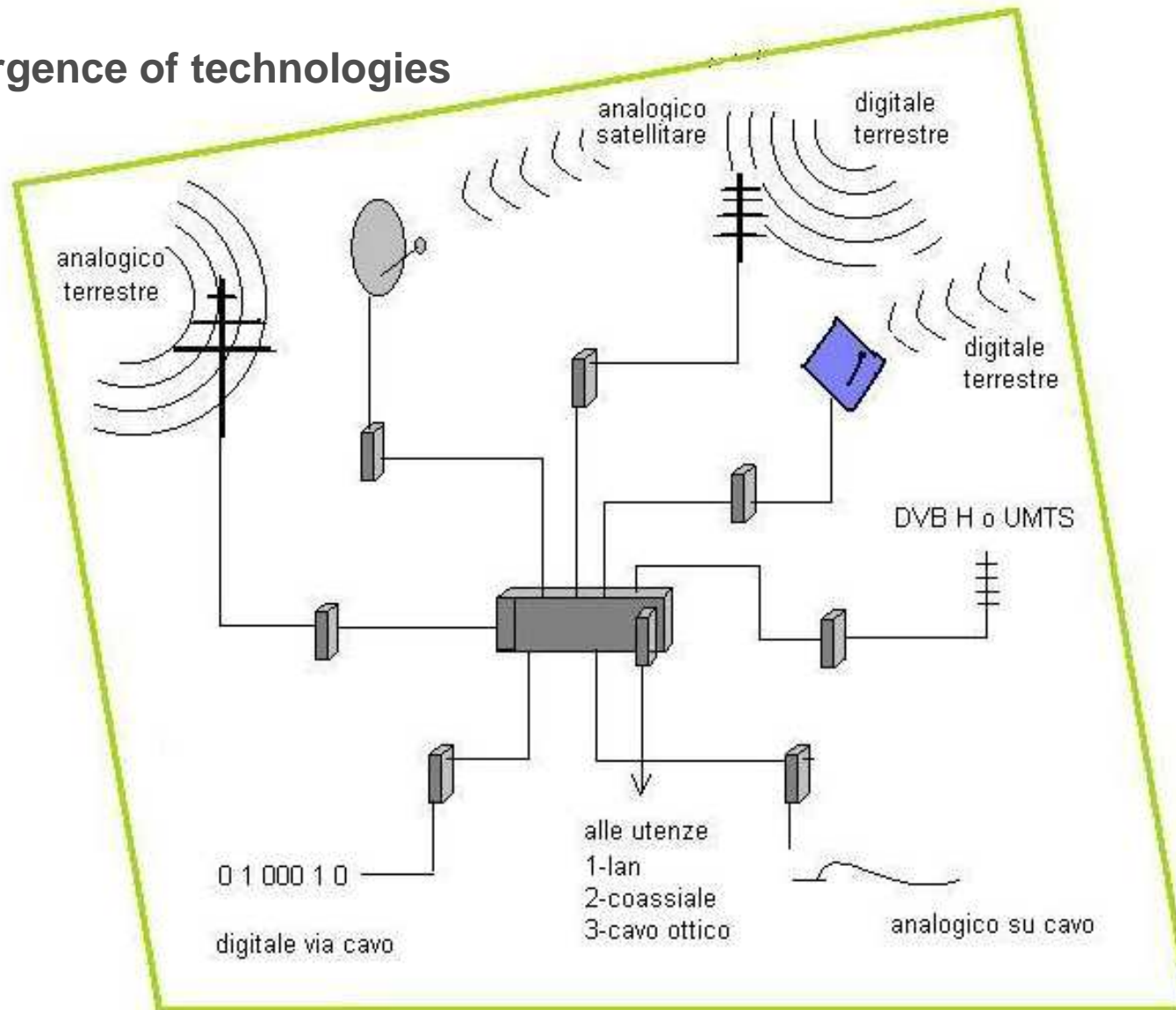

**Fracarro, from the Disk of Nipkow to the Digital Convergence**



**THANKS FOR YOUR ATTENTION**